

LA-UR -96-1907

CONF-9606229--8

Los Alamos National Laboratory is operated by the University of California for the United States Department of Energy under contract W-7405 ENO-36

RECEIVED
JUL 19 1996
OSTI

Title: LOS ALAMOS HYDRODYNAMIC EXPERIMENTS ON NOVA

Author(s): Robert E. Chrien, Cris W. Barnes, Warren W. Hsing,
Gottfried T. Schappert, P-24;
Nelson M. Hoffmann, J. Bradley Beck, Glen R. Magelssen,
D. Palmer Smitherman, XTA

Submitted to: 24th European Conference on Laser Interaction with Matter

MASTER

By acceptance of this article, the publisher agrees that the U.S. government retains a nonexclusive, royalty free license to publish or reproduce the published form of this contribution, or to authorize others to do so, for U.S. Government purposes.

The Los Alamos National Laboratory requests that the publisher identify this article as work performed under the auspices of the U.S. Department of Energy.

Los Alamos

Los Alamos National Laboratory
Los Alamos, New Mexico 87545

FORM NO. 836 R4
ST. NO. 2629501

DISTRIBUTION OF THIS DOCUMENT IS UNLIMITED

DISCLAIMER

Portions of this document may be illegible in electronic image products. Images are produced from the best available original document.

LOS ALAMOS HYDRODYNAMIC EXPERIMENTS ON NOVA

R. E. CHRIEN, CRIS W. BARNES, J. B. BECK, N. M. HOFFMAN,
W. W. HSING, G. R. MAGELSEN, G. T. SCHAPPERT,
AND D. P. SMITHERMAN

*Los Alamos National Laboratory
MS E596, Los Alamos, NM 87545 USA*

We are performing experiments to study hydrodynamic perturbation growth in x-ray driven targets to test models used to analyze the stability of ignition targets. We use cylindrical implosions to directly image perturbation growth and "feed-through" to the inner surface in convergent geometry. The implosion trajectories and azimuthal structure of inner and outer marker layers on the cylinder are measured by axial radiography. Perturbation growth of 25 at a convergence ratio of two has been measured on the inner layer, in addition to the effects of hohlraum drive asymmetries, nonlinear mode saturation, mode coupling, and the deceleration phase of the implosion. In other experiments, we are studying the planar analog of instability coupling between the inner surface of a cryogenic ignition capsule and the ablation surface. This instability coupling mechanism provides an important seed for perturbation growth in ignition capsule implosions.

1 Introduction

The Los Alamos inertial confinement fusion (ICF) program is performing experiments to test computational models used to analyze the stability of x-ray-driven capsule implosions, such as capsules for the proposed National Ignition Facility (NIF). The leading capsule design for reaching ignition and moderate gain is cryogenic with a solid deuterium-tritium (DT) shell surrounding a central DT gas region, and surrounded by a plastic ablator.^{1,2} By carefully shaping the radiation temperature in the hohlraum, the central gas region is heated and compressed to ignition conditions of areal density $\rho R \sim 0.3 \text{ g/cm}^2$ and ion temperature $\sim 10 \text{ keV}$. The fusion burn in the central "hot-spot" then propagates into the colder DT shell, which constitutes the main fuel. Hydrodynamic instabilities, which create perturbations at the interface between the gas and the main fuel, pose a major threat to hot-spot ignition by increasing thermal conduction losses from the hot-spot and by reducing the compressional heating and compressed density of the gas. Computational models^{2,3,4} suggest that NIF capsules will fail to ignite if perturbation amplitudes at the gas fuel interface exceed 30% of the hot-spot radius. Through experiments on the Nova laser at Livermore, we are testing the accuracy of these computational models to predict the most important initial perturbations in the capsule, the growth and nonlinear evolution of hydrodynamic instabilities, and the radial transport

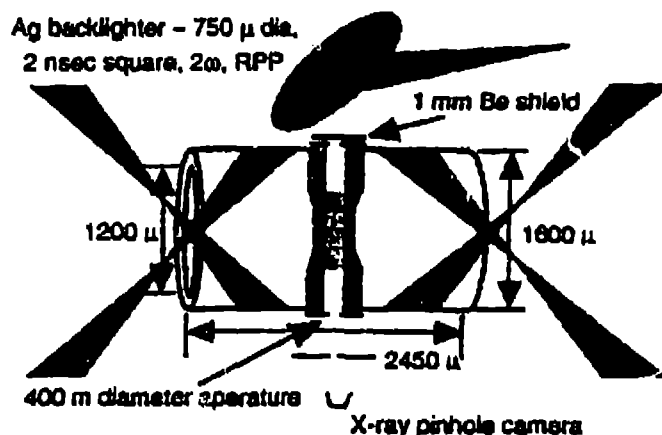

Figure 1: Experimental configuration for x-ray-driven cylinder implosions. An x-ray backlighter and gated x-ray pinhole camera are used to image the cylinder as it implodes. The cylinder is filled with low-density plastic foam to observe deceleration. The ablator layer is monobromostyrene to increase instability growth and minimize preheat. End effects are reduced by tapering the radial thickness of the cylinder. Parallax effects are avoided by using a short dichlorostyrene radiographic marker layer near the center of the cylinder.

of perturbations between different interfaces in the capsule.

2 Cylinder Implosions

Perturbation growth and transport in convergent geometry can be directly observed with cylinder implosions (Fig. 1). This experiment is complementary to planar Rayleigh-Taylor instability measurements,⁵ which lack convergent effects, and spherical capsule implosions,⁶ in which the perturbation growth on the inner surface is diagnostically inaccessible. An azimuthal perturbation is machined on the outer surface of the cylinder during fabrication. The sequence of gated images (Fig. 2) shows the radial implosion of the marker layer on the inner surface of the cylinder and the appearance of the $m = 10$ perturbation at this surface. Thus the effects of Rayleigh-Taylor instability at the ablation surface and perturbation transport to the inner surface ("feed-in") are directly observed. Perturbation amplitudes after feed-in as high as 25 times the initial amplitude at the outer surface have been observed, well into the nonlinear phase of the instability. Many other effects have been seen, including a P_4 radiation drive asymmetry, mode coupling between the imposed perturbation and drive asymmetry, interaction of multiple initial modes, self-emission from

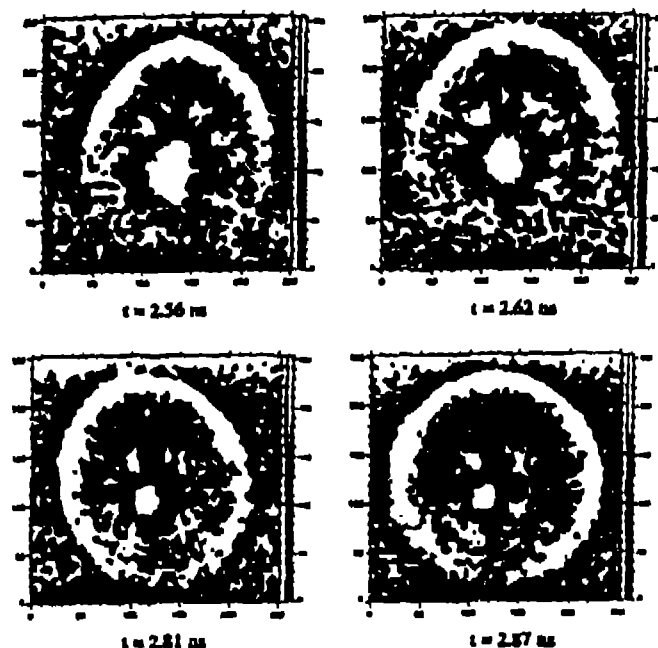

Figure 2: A sequence of gated pinhole camera images of a cylinder implosion. The dark inner ring is the marker layer. The perturbations are the result of Rayleigh-Taylor instability growth at the ablation surface and perturbation transport to the inner surface of the cylinder.

shock convergence on axis, and cylinder stagnation and re-expansion. The implosion trajectories of the ablator and marker layers, in the absence of imposed perturbations, provide a sensitive test of the opacities, equations-of-state, and radiation drive used in the simulations. Experiments are currently in progress to measure the dependence of growth rate and nonlinear saturation on mode number for initially sinusoidal perturbations.

3 Instability Coupling Experiments

Computational modeling³ suggests that a dangerous seed for instability growth in NIF capsules is the inner surface roughness on the DT ice. It is believed that the first shock to reach this perturbed interface develops a Richtmyer-Meshkov instability. The flow field of this instability transports the perturbation to the ablation surface, where it grows due to the ablative Rayleigh-Taylor instability. The perturbation later couples to the inner surface and grows further during deceleration. For NIF capsules with a plastic ablator, ignition is predicted to fail for DT ice roughness of $\sim 2\mu\text{m rms}$, only 2-3 times greater than the best fabrication capability. Capsules with a beryllium ablator are predicted to be less sensitive to DT ice roughness.³

We are performing experiments to test our modeling of instability coupling phenomena. These experiments are very similar to planar Rayleigh-Taylor

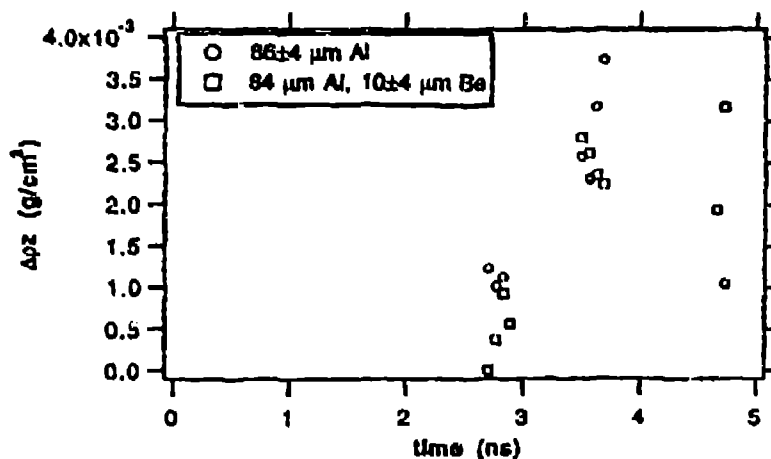

Figure 3: Measurements and simulations of $\Delta\rho_z$ for 50- μm wavelength, 4- μm amplitude initial perturbations on the cold side of an x-ray-driven planar aluminum sample.

instability studies,⁵ except that the initial perturbation is on the side of the planar package away from the x-ray drive. For the first experiments, we used an aluminum ablator to minimize preheat effects. The perturbation was carried by the aluminum or by a thin beryllium layer deposited on the aluminum. The perturbed areal densities were measured by face-on radiography using a 6.7-keV Fe backlighter (Fig. 3). The perturbations were observed to reverse phase, as expected, and are in reasonable agreement with the simulations. In subsequent experiments, we plan to vary the materials to better understand the apparent differences between NIF capsule ablators.

References

1. J. D. Lindl, *Phys. Plasmas* 2, 3933 (1995).
2. S. W. Haan, et al., *Phys. Plasmas* 2, 2480 (1995).
3. W. J. Krauser, et al., *Phys. Plasmas* 3, 2084 (1996).
4. N. M. Hoffman, et al., these proceedings.
5. B. A. Remington, et al., *Phys. Fluids B* 5, 2589 (1993).
6. O. L. Landen, et al., *Jour. Quant. Spectr. Rad. Trans.* 5:1, 215 (1995)

DISCLAIMER

This report was prepared as an account of work sponsored by an agency of the United States Government. Neither the United States Government nor any agency thereof, nor any of their employees, makes any warranty, express or implied, or assumes any legal liability or responsibility for the accuracy, completeness, or usefulness of any information, apparatus, product, or process disclosed, or represents that its use would not infringe privately owned rights. Reference herein to any specific commercial product, process, or service by trade name, trademark, manufacturer, or otherwise does not necessarily constitute or imply its endorsement, recommendation, or favoring by the United States Government or any agency thereof. The views and opinions of authors expressed herein do not necessarily state or reflect those of the United States Government or any agency thereof.